

# V - VLC

Version API 610 (VS4) available  
upon request

Long shaft, vertical sump pumps

## Industrial applications :

- Fertilizer plants
- Iron and steel industry
- Chemical industry
- Petrochemical industry
- Oil and Gas
- Various industrial applications

## Benefits :

- Heavy duty construction
- Low maintenance
- Available with multiple hydraulic designs

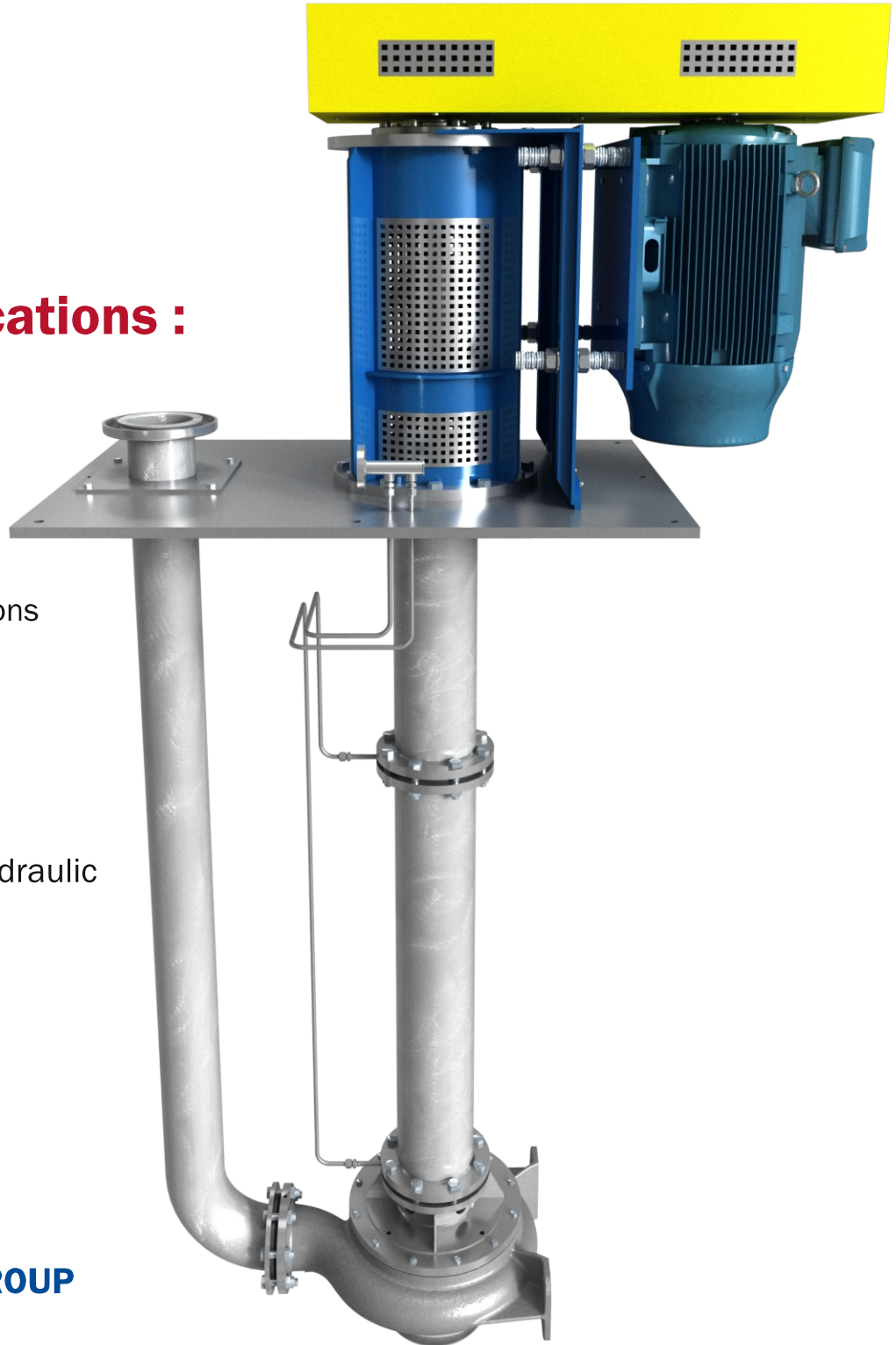

**ISO 9001 CERTIFIED GROUP**

 **Ensival Moret**  
A Moret Industries Company

## / Design :

- Designed to accept all types of hydraulics : semi-open, open or torque flow impeller : suitable for all kinds of liquids. (Pumps type : VL / VM)
- Pump length up to 16m (52ft) (higher sizes upon request)
- **Sealing options :**
  - for contaminated liquids : single or double mechanical seal
  - for clear liquids : without sealing systems
- **Shaft guided by column bearings with various Lubrication options :**
  - by the pumped fluid (discharge recirculation via filters or cyclone separators to lubricate line bearing(s))
  - external flush option (with water or compatible fluid)
  - grease lubricated roller bearing (<50 °C) or oil lubricated bearing (>50 °C)
- Discharge separate from the shaftline.
- Can be supplied with a V-Belt drive
- Optional suction strainer

## / Performances and operating range :

- Flow : up to 3300 m<sup>3</sup>/h (14,500 US gpm)
- Total head : up to 100 m (500 ft)
- Maximum operating pressure : 20 bar (290 PSI)
- Operating temperature range : up to 120 °C (up to 248 °F)
- Higher capacities and heads upon request

## / Standard materials of construction :

- Grey cast iron, chromium iron.
- Austenitic or ferritic-austenitic stainless steel of all grades.
- Special alloys available upon request.

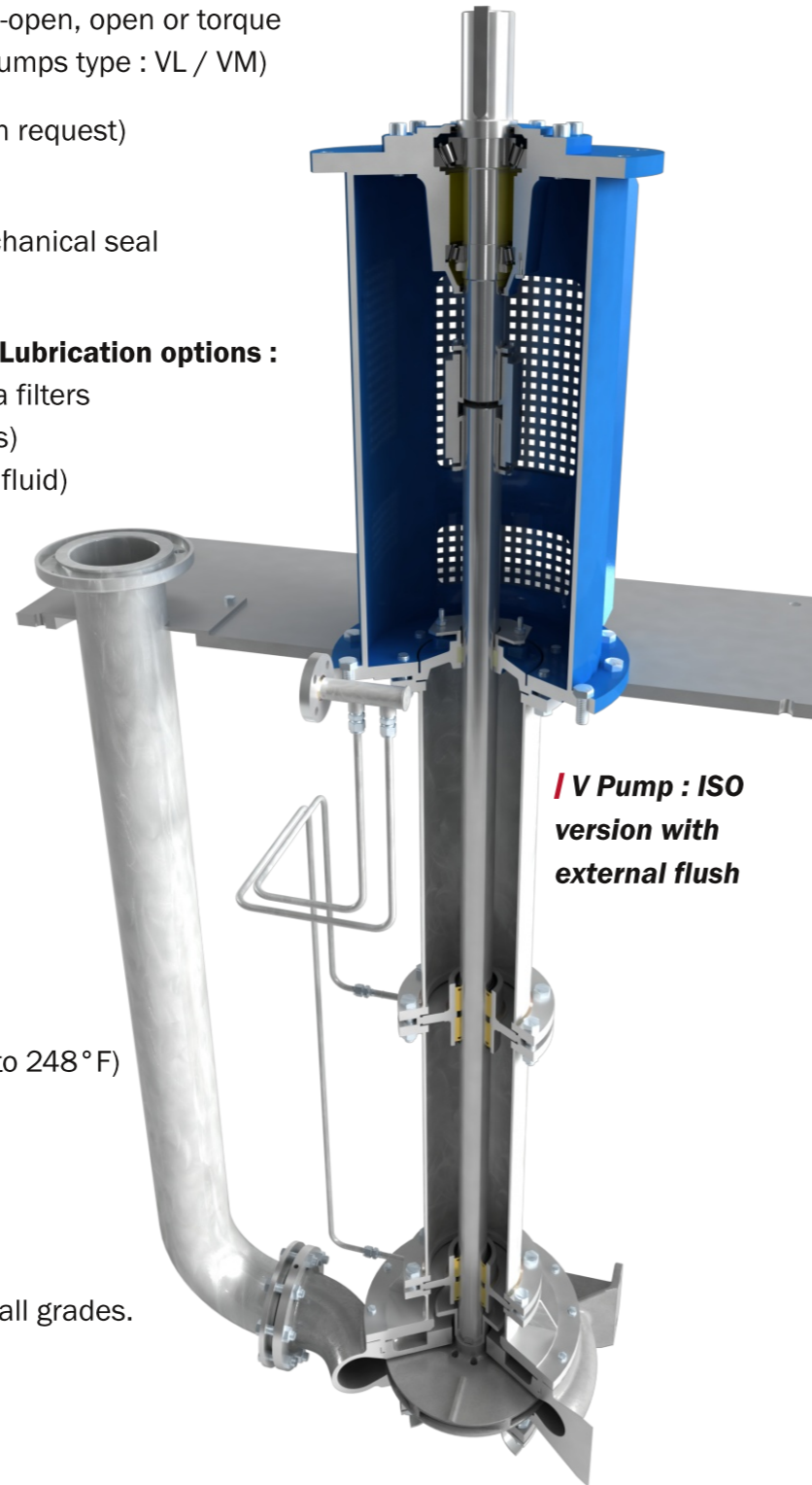

## Type of hydraulics units

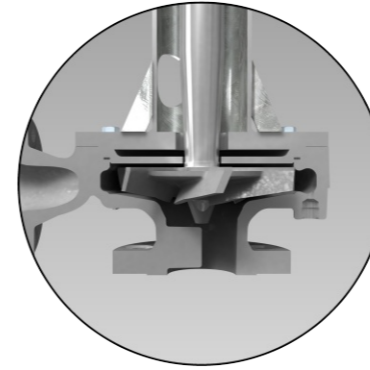

**/ Open impeller :**  
For contaminated liquids and slurry. Open impeller provide an efficient solids handling.

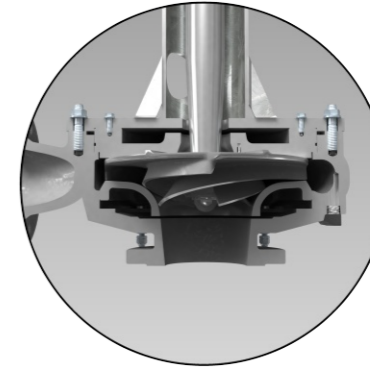

**/ Semi-open impeller :**  
For liquids with low solids content, aerated or encrusting.

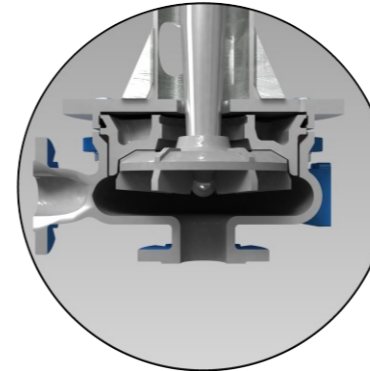

**/ Recessed impeller pump :**  
For aerated liquid or containing large size solids (non-clogging pump).

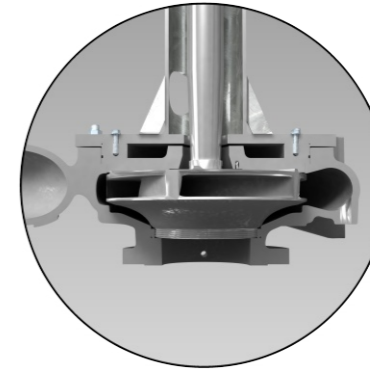

**/ Closed impeller :**  
For clear and non-encrusting liquid, a closed impeller provides better efficiency and higher heads.

## General hydraulic coverage

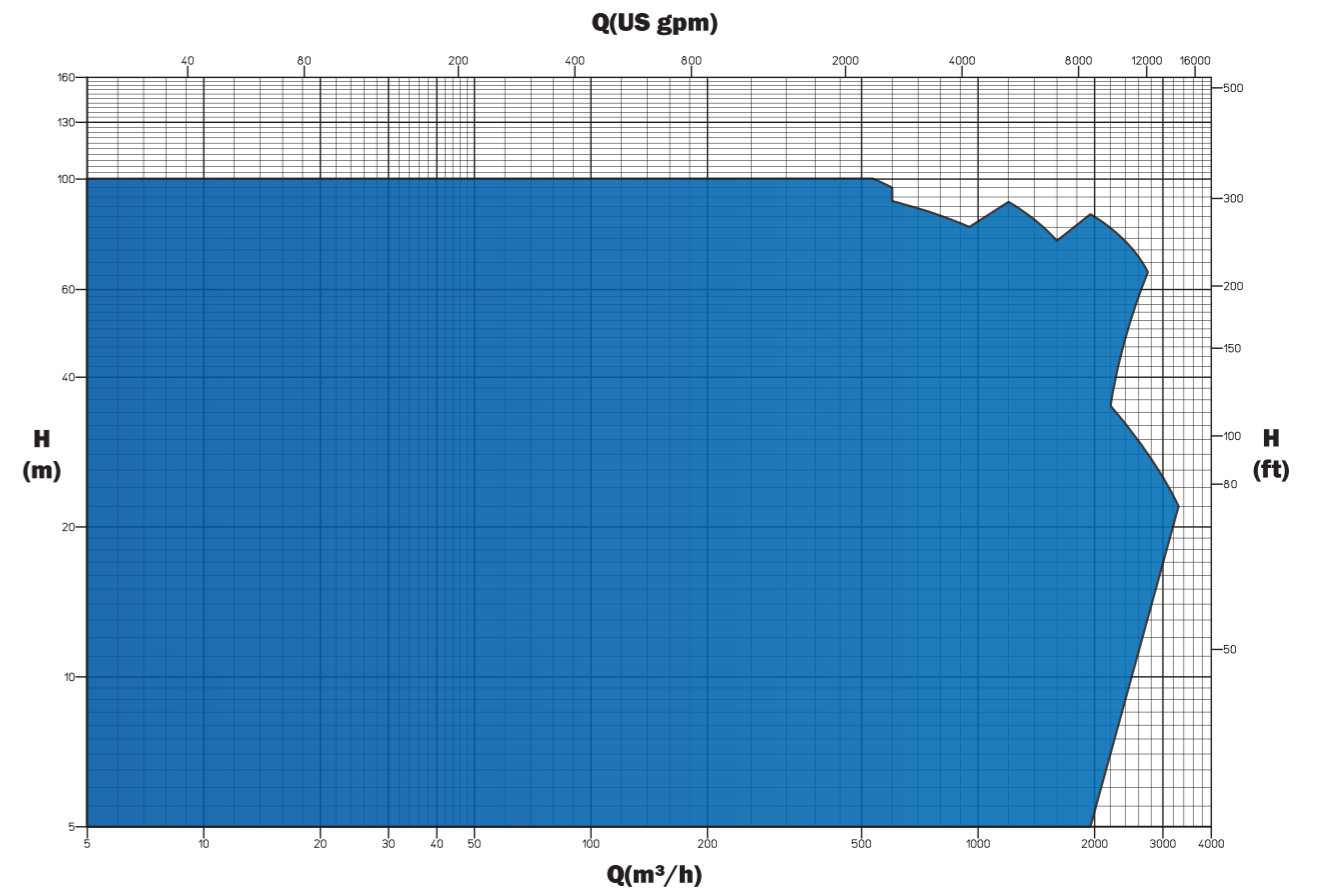

## / HIGH FLEXIBILITY AND MAXIMUM RELIABILITY

## VLC : API VERSION

The VLC pump API 610 (VS4) is specially designed to comply with the latest edition of API 610. Thanks to a modular and flexible design, the VLC pump can be designed and manufactured for the most specific applications according to your requirements.

### / Design :

- A complete range of hydraulics cells (150 lbs or 300 lbs)
- Grease or oil lubricated upper bearing
- Sealing Options : cartridge seals, unpressurized or pressurized dual mechanical seals
- Highly corrosion and abrasion-resistant bushings lubricated by the solids free pumped liquid.
- Alternative lubrication options available if the pumped liquid is not suitable for lubrication of column bearings.
- Lineshaft bearings are available in various materials : PEEK, PTFE, carbon, silicon carbide, stellite, nitronic... (dependent on pumped liquid)
- Baseplate : optional vapour proof design through a wide range of sealing arrangement to avoid environment contamination
- Circular baseplate (ANSI 150 LBS, or ANSI 300 LBS) or rectangular

### / Performances and operating range :

- Flow : up to 2000 m<sup>3</sup>/h (14,500 US gpm)
- Total head : up to 100 m (330 ft)
- Maximum operating pressure : 40 bar (580 PSI)
- Operating temperature range :  
up to 200°C (up to 752°F)

### / Standard materials of construction :

- Materials per API standard :  
S5, S6, C6, A8, D1, D2.
- Other materials available upon request

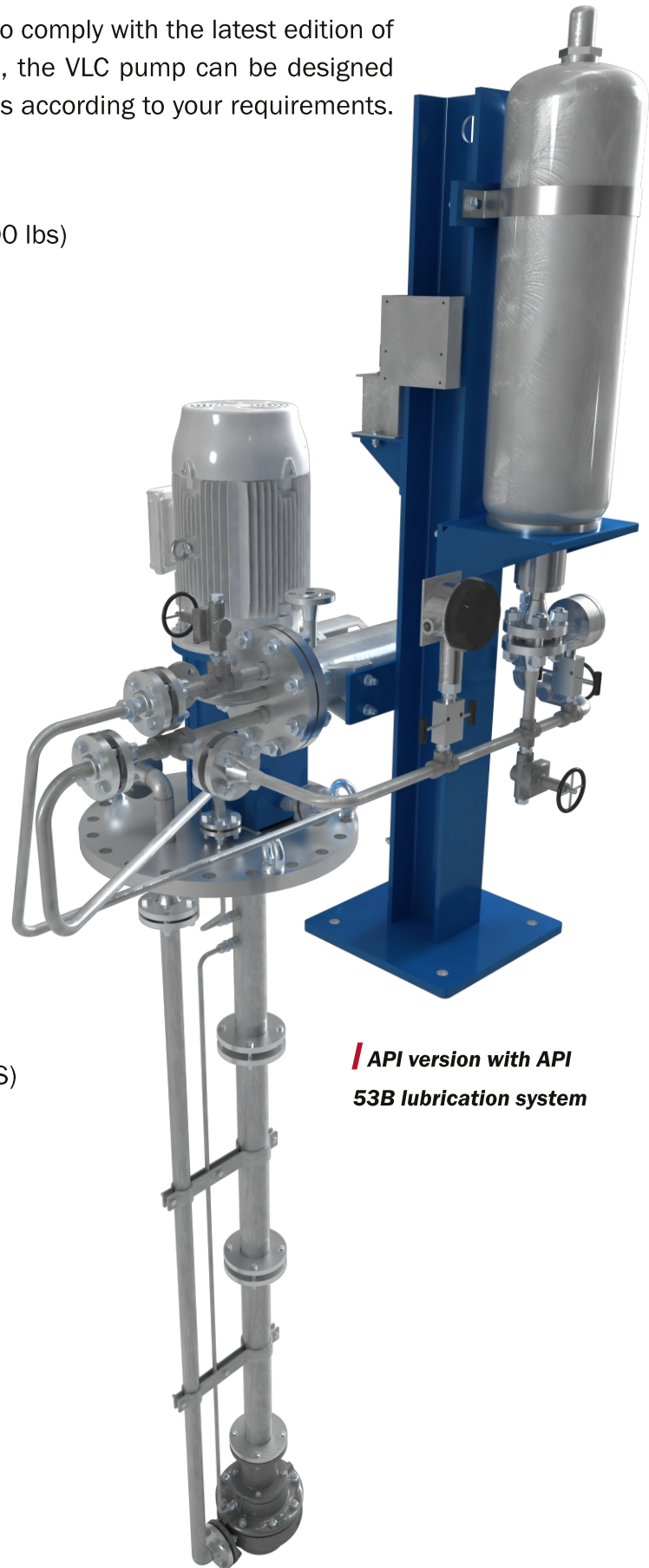

**/ API version with API  
53B lubrication system**

## With tandem mechanical seals

/ In this case, two mechanical seals mounted in tandem arrangement in the adapter frame ensure the shaft sealing between hydraulic cell and hang pipe. The chamber provided between the two seals is filled with a sealing liquid, usually oil, and connected to the seal pot located above grade level via a piping.

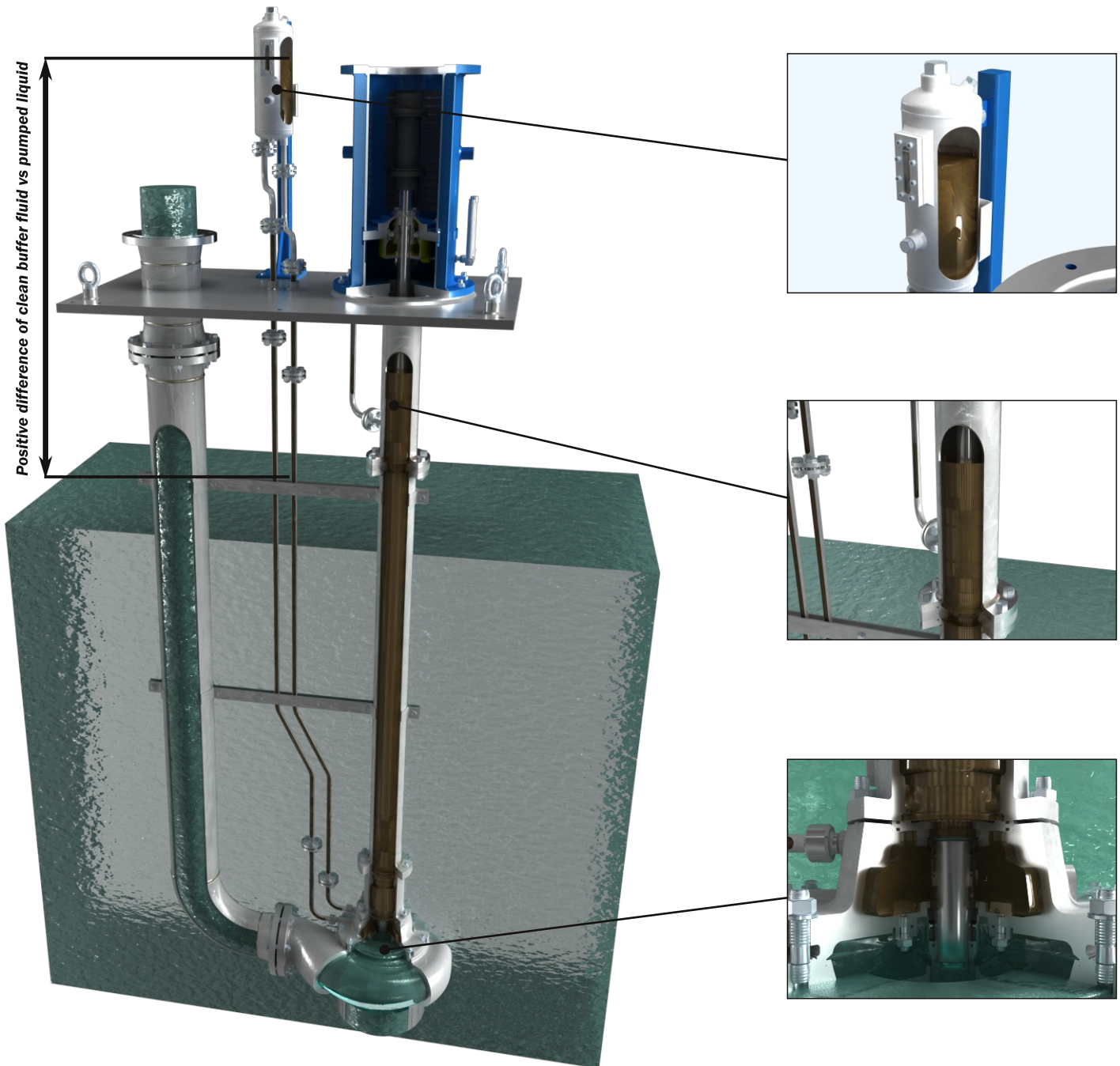

/ The lower mechanical seal is thus subject to a pressure equivalent to the liquid height in the sump while upper mechanical seal is exposed to a pressure corresponding to the height of the buffer liquid between seal chamber and upper seal pot.

/ As the pressure of the buffer fluid exceeds the pressure of the pumped liquid, the mechanical seals will always be lubricated by a clean liquid.



#### **ENSIVAL MORET FRANCE**

Chemin des Ponts et Chaussées  
F-02100 Saint-Quentin  
Tel : +33 (0)3 23 62 91 00  
Fax : +33 (0)3 23 62 02 30  
Email : emstquentin@em-pumps.com

#### **ENSIVAL MORET FRANCE**

59 Avenue du Danemark  
F-37100 Tours  
Tél : +33 (0)2 47 88 31 31  
Fax : +33 (0)2 47 41 51 73  
Email : emtours@em-pumps.com

#### **ENSIVAL MORET FAPMO**

35, 37 Rue Roger Salengro BP59  
F-62230 Outreau (FRANCE)  
Tel : +33 (0)3 21 10 01 21  
Fax : +33 (0)3 21 80 46 88  
Email : fapmo@em-pumps.com

#### **ENSIVAL MORET AMERICA, Inc.**

7901 SouthPark Plaza, Suite 102  
Littleton, Colorado 80120, USA  
Office : 303-798-4454  
Fax : 303-798-4199  
sales@em-america.com

#### **ENSIVAL MORET BELGIUM**

Bois-la-Dame, 4 Z.I. les Plenesses  
B-4890 Thimister-Clermont  
Tel : +32 (0)87 46 81 11  
Fax : +32 (0)87 46 81 00  
Email : info@em-pumps.com

#### **ENSIVAL MORET DEPLECHIN**

Avenue de Maire, 28  
B-7500 Tournai (BELGIUM)  
Tel : +32 (0)69 89 00 89  
Fax : +32 (0)69 89 00 60  
Email : emtournai@em-pumps.com

#### **ENSIVAL MORET ASIA**

31 Mandai Estate  
#07-07 Innovation Place - Tower 4,  
Immedia  
Singapore 729933  
Tel : +65 6281 06 67  
Fax : +65 6281 09 08  
Email : emsingapore@em-pumps.com

#### **ENSIVAL MORET INDIA Pvt. Ltd.**

702A Oxford Hallmark  
Lane 7 Koregaon Park  
Pune 411 001 - INDIA  
Tel: +91 (0)20 4128 5783  
Email: emindia@em-pumps.com

#### **ENSIVAL MORET (SHANGHAI) CO., LTD.**

No. 1590, Li An Road,  
Minhang District,  
Shanghai 201199 - P.R. CHINA  
Tel: +86 (0)21 5488 9599  
Fax: +86 (0) 21 5488 9399  
Email: emshanghai@ensival-moret.cn

#### **ENSIVAL MORET DO BRAZIL**

Distrito Industrial Bandeirantes  
Rua País de Gales, 128  
CEP 13.326-195 Salto-SP - BRASIL  
Tel/Fax : (55) 11 4602 9595  
Email: info@em-brasil.com