

ROTO-PRIME®

SELF-PRIMING CENTRIFUGAL PUMPS

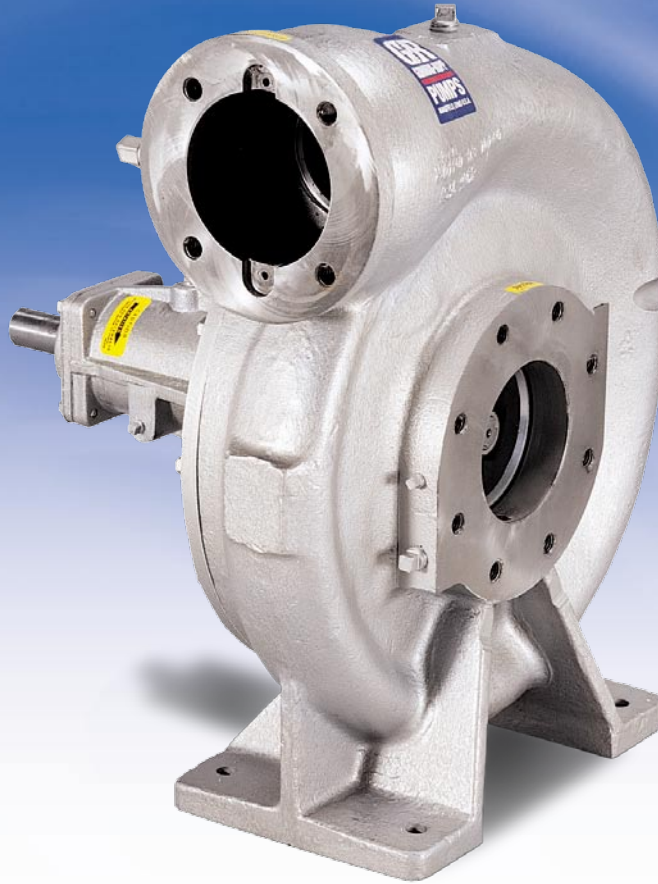

Self-Priming Petroleum Pumps

Roto-Prime® self-priming centrifugal pumps are specifically designed for pumping petroleum products, petrochemicals and solvents. The Roto-Prime design incorporates a variable capacity vane pump which quickly and automatically evacuates air and vapor, making them ideal for loading, off-loading transports and stripping hoses.

ROTO-PRIME PROVIDES AUTOMATIC, POSITIVE PUMPING

Whenever air or vapor is present at the start of the pumping operation – or when there is a loss of suction because of air or vapor during pumping – the priming pump automatically moves air and vapor from the suction line to discharge line. Once the flowing liquid from the centrifugal portion of the pump builds up sufficient pressure in the discharge system, the pressure backs up through a tube to act on the bottom of the priming pump’s movable slide block, placing it in a neutral position. Under these conditions the priming pump no longer evacuates a small amount of liquid.

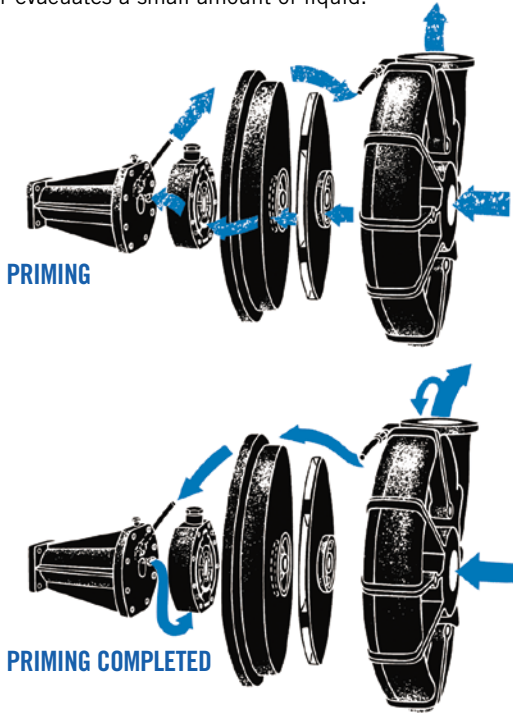

ROTO-PRIME SELF-PRIMING CENTRIFUGAL PUMPS



Full Priming

Full Priming – With air or vapor in the lines, pressure of the spring on top of the movable slide holds the priming pump in full pumping position.



Partial Priming

Partial Priming – As the pump evacuates air and vapor from the lines, liquid pressure builds up on the underside of this slide, moving it upward toward neutral.

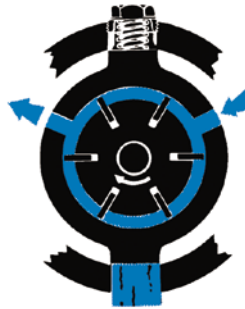

Neutral

Neutral – When air and vapor are removed, liquid pressure equalizes spring pressure and the pump automatically slides into neutral... where it remains until air and vapor again appear in the system.

Roto-Prime pumps are actually two pumps in one. The small powerful vane-type pump within the main centrifugal housing can prime an absolutely dry 4 inch (102mm) line with zero back pressure in approximately two seconds per foot without initial manual priming. And, this priming pump will evacuate suction lines against back pressures up to 8 pounds per square inch.



OPTIONAL AIR RELEASE

The GRP33-06 air release valve evacuates air in the suction line to ensure positive self-priming even when pumping against moderate to high static heads.

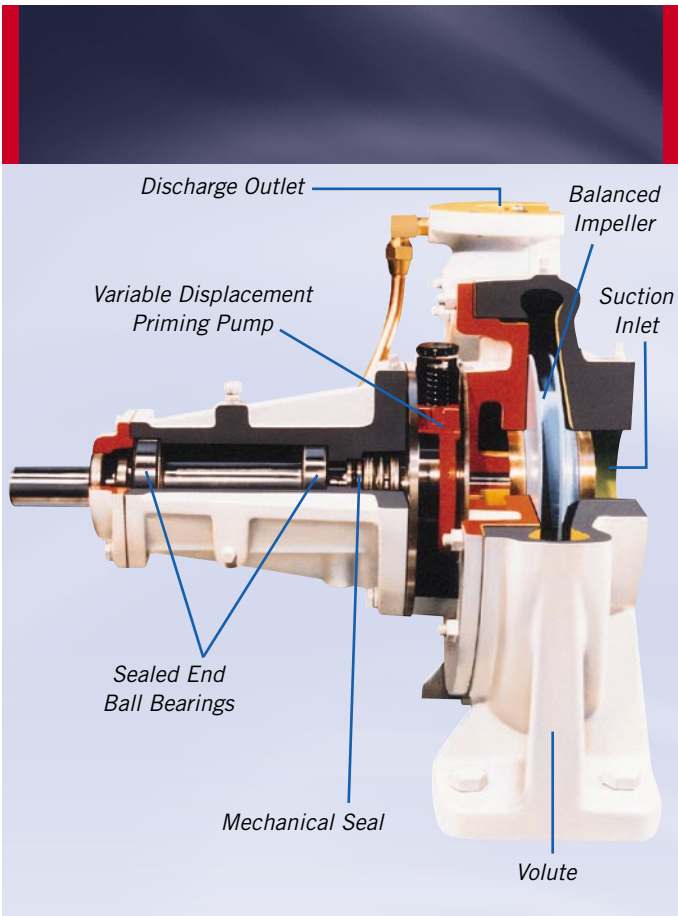



MATERIALS OF CONSTRUCTION

Pumps have rugged ductile iron or cast steel housings, heavy-duty steel or stainless steel shafts, fluorocarbon fitted mechanical shaft seal with aluminum impellers. Consult the factory for optional Teflon® seals for today's liquid requirements.

Sizes range from 3" x 2" (76.2mm x 50.8mm) up to 6" x 5" (152.4mm x 127mm), capacities to 1450 gpm (91.3lps), heads to 390 feet (118.9m).

The single volute (RS) pump operates at 1750 rpm, with the double volute (RD) pump operating at 3450 rpm.

OPTIONAL ACCESSORIES

Stainless steel pump shafts, bronze impellers, companion flanges, swing check valves and mechanical seals are available to meet today's pumping needs.

Teflon® is a registered trademark of E. I. DuPont

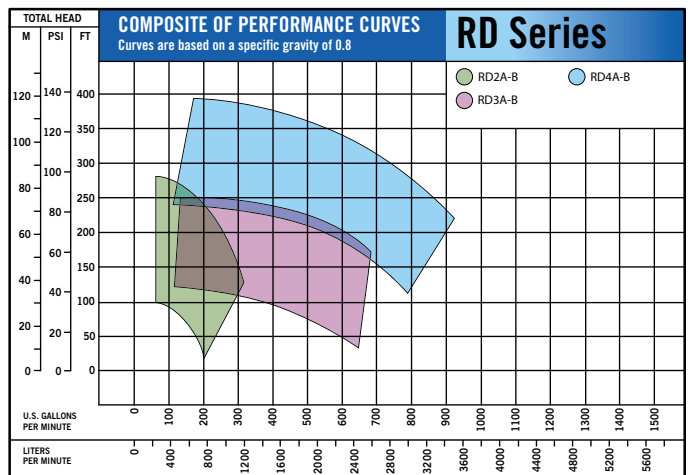
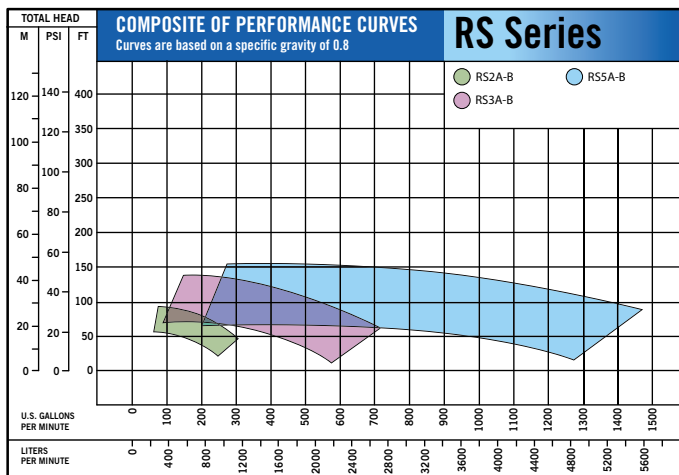



Learn More about Gorman-Rupp Roto-Prime Pumps

For more information on Gorman-Rupp Petroleum pumps go to
www.GRpumps.com

Product information is subject to change; consult factory for details.



The Gorman-Rupp Company
Mansfield Division
 P.O. Box 1217
 Mansfield, Ohio 44901-1217
 Tel: 419-755-1011
 Fax: 419-755-1251
 E-mail: grsales@gormanrupp.com

Gorman-Rupp International
 P.O. Box 1217
 Mansfield, Ohio 44901-1217
 Tel: 419-755-1011
 Fax: 419-755-1266
 E-mail: intsales@gormanrupp.com

www.GRpumps.com

Gorman-Rupp of Canada, Ltd.
 70 Burwell Road
 St. Thomas, Ontario N5P 3R7, Canada
 Tel: 519-631-2870
 Fax: 519-631-4624
 E-mail: grcanada@grcanada.com

