



# Hydrovar<sup>®</sup> and Packaged Hydrovar<sup>®</sup>

MOTOR MOUNT VARIABLE SPEED PUMP CONTROLLER AND INTEGRATED PUMP PACKAGES

BRHYDROVAR R2

 **GOULDS**  
WATER TECHNOLOGY  
a xylem brand

# Goulds Water Technology

Hydrovar and Packaged Hydrovar

## Hydrovar Variable Speed Drives



Fully programmable variable speed drives in space saving pump-mounted design

The Hydrovar controller is a combination of a variable frequency drive and a programmable logic controller (PLC) in one compact package, which can be mounted on the fan cover of a TEFC pump motor. Drives are pre-programmed with patented pump specific software, designed for centrifugal pumps. They match pump output to a wide range of system conditions while protecting the pump, the motor and the pumping system.

Hydrovar drives provide superior system pressure control over a wide range of flow rates. As demand changes the drive adjusts the speed of the motor to compensate, keeping output pressure nearly constant.

And Hydrovar drives reduce energy usage and cost. By slowing the speed of the pump, the Hydrovar eliminates the inefficiencies of full speed systems. With lower energy and maintenance costs they can pay for themselves in under 2 years!



# Hydrovar Variable Speed Drives

Hydrovar drives are factory configured with different components to create three distinct drive types.\*

- A **SINGLE** drive includes a control card and a display for complete variable speed control of only one pump.
- A **MASTER** drive includes a control card, display and communication card for full variable speed control of one pump, and for system control of multi-pump applications.
- A **BASIC** drive has the basic power module and a communication card. It can be used with a Master drive in multi-pump applications. It can also be used as a full speed soft starter on a single pump.

\* Drives cannot be upgraded to a different type in the field.

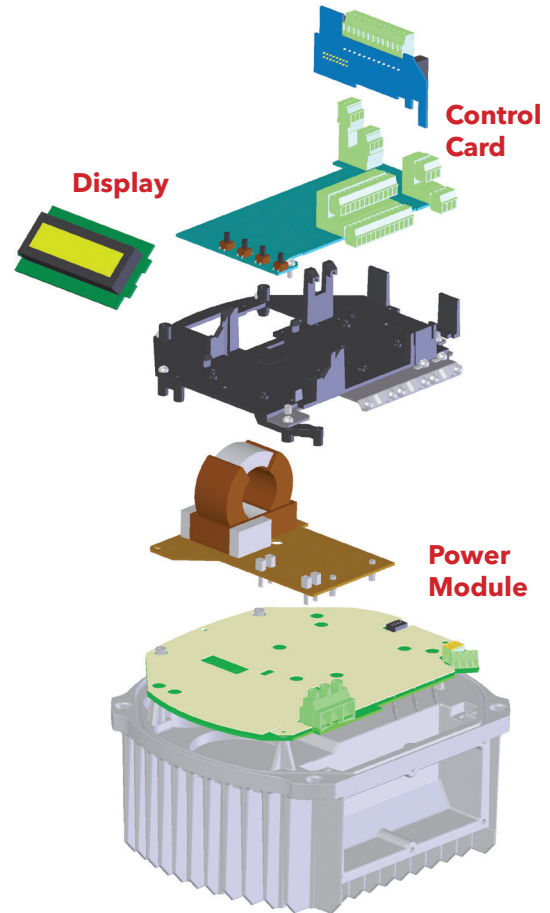

## Three drives.....Three different applications:

**1) Single Drive:** Full variable speed control

**2) Basic Drive:** Soft start full speed only

**3) Master Drive with 1 or more Basic Drives\***

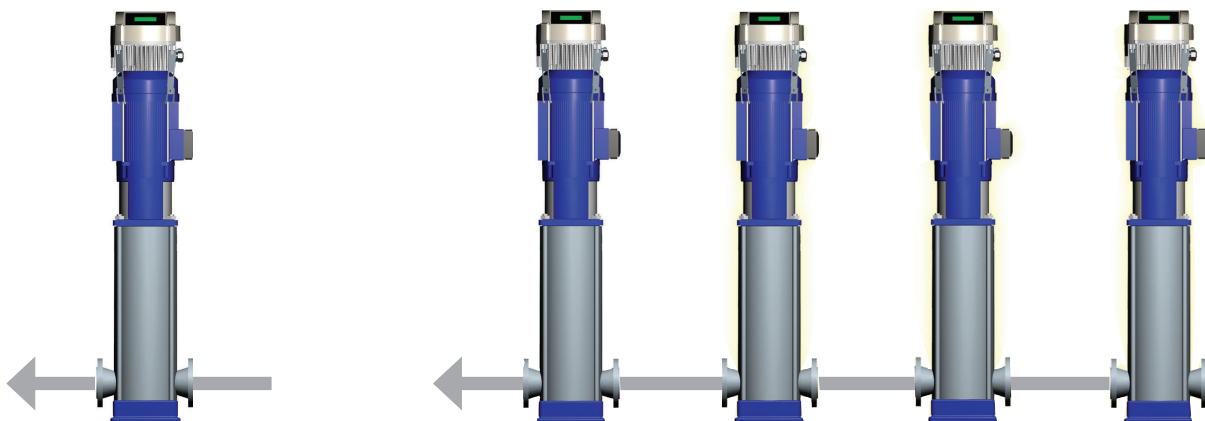

\*Requires at least one Master Drive. Increase system flexibility with 2 or more Masters.



# Goulds Water Technology

Hydrovar and Packaged Hydrovar

## The Hydrovar Advantage

- Constant pressure with varying demand
  - Hydrovar varies the pump speed as flow rates change
- No external contactors, PLC's, or motor protection required
- Lower system maintenance costs
  - Less equipment to buy and maintain
  - Fewer starts and stops
  - Eliminates water hammer
  - No PRV valves or recirculation systems
- Space saving design: Drive mounted directly on vertical pump motor, with significantly smaller diaphragm tank.
- Software designed FOR pumps by pump engineers
- Control up to 8 pumps with full variable speed control
  - Use combination of master and basic drives for most economical system solution
- Control up to 5 full speed pumps using 1 drive (with optional relay card and motor starters)
- MODBUS compatible
- Uses 4-20mA transducer similar to Aquavar product, 0-300 psi range. **Transducer (sensor) included with drive!**





## The Hydrovar Advantage

- Accepts 3 different signal inputs: 0-20mA; 4-20mA and 0-10VDC
- Master, Basic and Single drive options provide flexibility at lower cost
- Error log and diagnostic display shows temperature and real time current and voltage
- Simplified programming menu
- Multiple set points available
- 3 Separate start/stop inputs
- Use with OFF-the-shelf TEFC 3Ø motors
- KITS offer prewired drive and fused disconnect to retrofit pumps in the field
- Complete e-SV Packages offer
  - Industry leading efficiencies
  - Broad performance range
  - Simple selection and ordering process
  - Factory programed and tested system





# Goulds Water Technology

Hydrovar and Packaged Hydrovar

## Hydrovar Variable Speed Control



Pump Mounted Variable Speed Controller



Packaged Hydrovar

**NOTE:** e-SV Pump, Drive, Pressure Transducer, fused disconnect, complete wiring and conduit included.

### Available Configurations

Horsepower Range	Electrical Requirement
2 and 3	1Ø, 230 V input; 3Ø, 230 V output
3, 5, 7½, 10, 15	3Ø, 460 V input; 3Ø, 460 V output

### Technical Data

**Single Phase Input Version:** 2 and 3 HP

**Motor Requirement:** 3 phase, TEFC, 208 - 230 volt, 0 - 60 HZ, Class F insulation

**Power Supply:** single phase input, 220 - 240 volt, ±10%, 40 - 70 HZ

**Three Phase Input Version:** 3 HP to 15 HP

**Motor Requirements:** 3 phase, TEFC, 460 volt, ±10%, 0 - 60 HZ, Class F insulation

**Power Supply:** 3 phase, 380 - 460 volt, ±10%, 40 - 70 HZ

**Pressure Transducer:** 316 SS, 17-4 PH stainless steel, ¼" NPT connection, shielded two wire cable, operating temperature -13° F to 250° F, supply voltage 7- 35 Vdc, 4 - 20mA output. Accuracy is .5% of full scale, proof pressure is 4 x full scale.

**Display:** Two line, 16 characters per line, LCD display. Easy to read pump language, pump on, system pressure, fault codes and system conditions are displayed.

**Motor Speed:** Variable between 0 - 70 HZ , or maximum RPM at 60 HZ depending on speed rating of standard AC induction motor.

**Ambient Temperatures (operating):** 32 - 104° F (0 - 40° C)

**Humidity:** 50% relative at 104° F (non-condensing)  
90% relative at 68° F (non-condensing)

**Inverter design:** IGBT, output frequency is a sinus valuated Pulse Width Modulated (PWM)

**Enclosure:** NEMA 4, IP 55. Avoid excessive dust, corrosives or salts.

**Safety Agency Listings:** Hydrovar, Hydrovar Kit, and Packaged Hydrovar incorporate UR (UL recognized Components). The Packaged Hydrovar will be cUL listed in March 2013.

**Protection:** Over/Under voltage, motor overload, short circuit, ground fault, motor over-heat (with thermistor), programmable no/low flow shut-down, low suction pressure, pump run-out.

**Control:** Analog input control (4 - 20mA) two point control based on pressure, flow or differential pressure. Control up to 8 pumps in parallel.

**Terminals:** Dry relay contacts are available for pump run, pump error, low pressure switch, remote ON/OFF control, analog output 0 - 10 Vdc (system pressure) and full opened slave pump starter.

**Multi-Pumps:** RS485 communication SIO (local only) up to four pumps.

**Alternate Input:** Up to two transducers may be used with each controller. These may be pressure, flow, differential pressure, temperature or other 4 - 20mA signals.

### Hydrovar Variable Speed Pump Controller

The HYDROVAR Pump controller is a combination of a variable frequency motor drive (VFD) and a programmable logic controller (PLC) in one compact package. It mounts on the fan cover of the TEFC pump motor. Each controller is pre-programmed with patented pump specific software. Controllers are specifically designed to work with all configurations of centrifugal pumps, matching pump output to varying system conditions while protecting the pump, the motor and the pumping system.



# Hydrovar Variable Speed Drive Type and Catalog Number

## Hydrovar Example Product Code

**HV M 3 4 15**

**HP Rating:**

02 = 2 HP    03 = 3 HP    05 = 5 HP  
 07 = 7.5 HP    10 = 10 HP    15 = 15 HP

**Voltage:**

2 = 230V    4 = 460V

**Phase:**

1 = Single Phase (2 and 3 HP)    3 = Three Phase (3-15 HP)

**Type:**

M = Master    S = Single    B = Basic

**Series: HV**

The following applies to both examples:  
 HV - Hydrovar Variable Speed Drive

M - Master Drive (full control and communications)

3 - 3 Phase input power

4 - 460 Volt input power

15 - Horsepower rating

KIT - Hydrovar Kit Assembly

## Hydrovar Kit Example Product Code

**HV M 3 4 15 KIT**

**Hydrovar Kit Assembly:**

Drive, disconnect and transducer pre-wired package

**HP Rating:**

02 = 2 HP    03 = 3 HP    05 = 5 HP  
 07 = 7.5 HP    10 = 10 HP    15 = 15 HP

**Voltage:**

2 = 230V    4 = 460V

**Phase:**

1 = Single Phase (2 and 3 HP)    3 = Three Phase (3-15 HP)

**Type:**

M = Master (only)

**Series: HV**

## Packaged Hydrovar/e-SV Example Product Code

**10 SV 7 F H 4 F 2 0 V3**

**Hydrovar Input Power (Phase)**

V1 = Single Phase    V3 = Three Phase

**1SV - 92SV Selections Available**

See e-SV Technical Manual and Price Sheets for pump / motor / options code selections.

**Note:** Packages and KITS will only be available with Master Drive Hydrovar. 300 PSI transducer is supplied as standard. All e-SV motors will be TEFC 3-phase construction.

**CAUTION:** Optional 500 PSI transducer measures accurately to 400 PSI. Pump, flanges and other piping system components must also be rated for the maximum system pressure. See e-SV technical manual and other appropriate technical manuals to verify all equipment is rated to maximum system pressure.



Goulds Water Technology is a global leader in the water technologies market, producing the world's leading line of residential water well pumps. The Goulds Water Technology product portfolio includes submersible and line shaft turbine, 4" submersible, jet, sump, effluent, sewage and centrifugal pumps for residential, agriculture and irrigation, sewage and drainage, commercial and light industrial use.

Also included are many pump control options for residential and commercial applications, including variable speed controllers, control panels and packaged booster systems.

For more information visit [www.gouldswatertechnology.com](http://www.gouldswatertechnology.com)



Xylem Inc.  
2881 East Bayard Street Ext.  
Seneca Falls, NY 13148  
Phone: (800) 453-6777  
Fax: (888) 322-5877  
[www.gouldswatertechnology.com](http://www.gouldswatertechnology.com)

Goulds is a registered trademark of Goulds Pumps, Inc. and is used under license. CentriPro, Aquavar, Aquavar ABII and Aquavar SPD are trademarks of Xylem Inc. or one of its subsidiaries.  
© 2011 Xylem Inc. BRHYDROVAR R2 April 2013