

HEAVY DUTY

Diaphragm Pumps



RamParts[®]
Pumps

RUGGED

Designed for Handling Heavy Sludges and Slurries

The rugged construction and extra-thick pump casing of RamParts air-driven diaphragm pumps stand up to the abuses of the most demanding sludge and slurry applications.

They overcome the “high-wear” problem commonly found in double diaphragm and progressive cavity pumps.

Air-driven diaphragm pumps are capable of operating dry on suction lifts up to 20 feet (6.5 m) and handling liquids with solids contents up to approximately 70%. Depending on pump model, they will pass up to

3" (76 mm) diameter spherical solids. (Solids size is determined by check valve type.)

Pump stroke rate, discharge stroke time, suction drive pressure and discharge drive pressure can all be adjusted independently. Pumps will easily handle heavy sludges at their rate of accumulation in clarifiers and settling basins.

When it comes to handling heavy sludges and slurries, there's only one name you need to know—RamParts.

RAMPARTS®

Typical Applications

Alcohol Plants

Auto Plants

Battery Recyclers

Cement Plants

Chemical Plants

Distilleries/Breweries/Wineries

Commercial Laundries

Food Processing Wastes

Foundries

Glass Plants

Meat Processing Plants

Mining

Paper Mills

Plating Plants

Potable Water Treatment

Power Plants

Refineries

Railroad Yards

Sand & Gravel Plants

Soap Manufacturing

Steel Mills/Iron Works

Tanneries

Textile Mills

Municipal Wastewater

Wire Manufacturers

Waste Activated Sludge (WAS)

Return Activated Sludge (RAS)

Ceramic Slip

Vitreous China Plants

4" (100 mm) pump handling wastewater in a sump application at a concrete plant in the Netherlands.

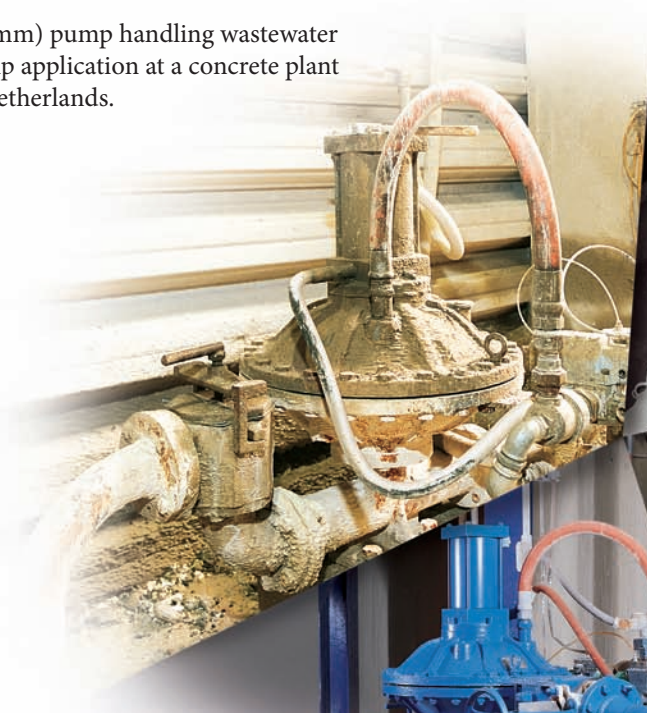

4" (100 mm) pump handling abrasive glass slurry at a glass manufacturing facility in Ohio.



Air-driven diaphragm pump handling reclaimed paper stock at a paper mill in Oregon.



Air-driven diaphragm pump in clarifier underflow application handling primary sludge at a waste treatment facility in Nevada.



Diaphragm-Assist Air Cylinder

Improved diaphragm life and pump speed control.

Heavy-Duty Construction
Rugged casting design coupled with heavy-duty diaphragm provides longer service life.

Check Valve Assembly

Allows for passage of large diameter solids and provides external access for inspection or service.

Optional Elastomeric Linings

Broad range of elastomer selections available for specific pump application.

Vertically Oriented Flow-Through Design

Pump configuration provides maximum solids-handling capabilities.

Free-Standing Base

Provides solid anchoring and stable operation of the pump to assist in installation and service.

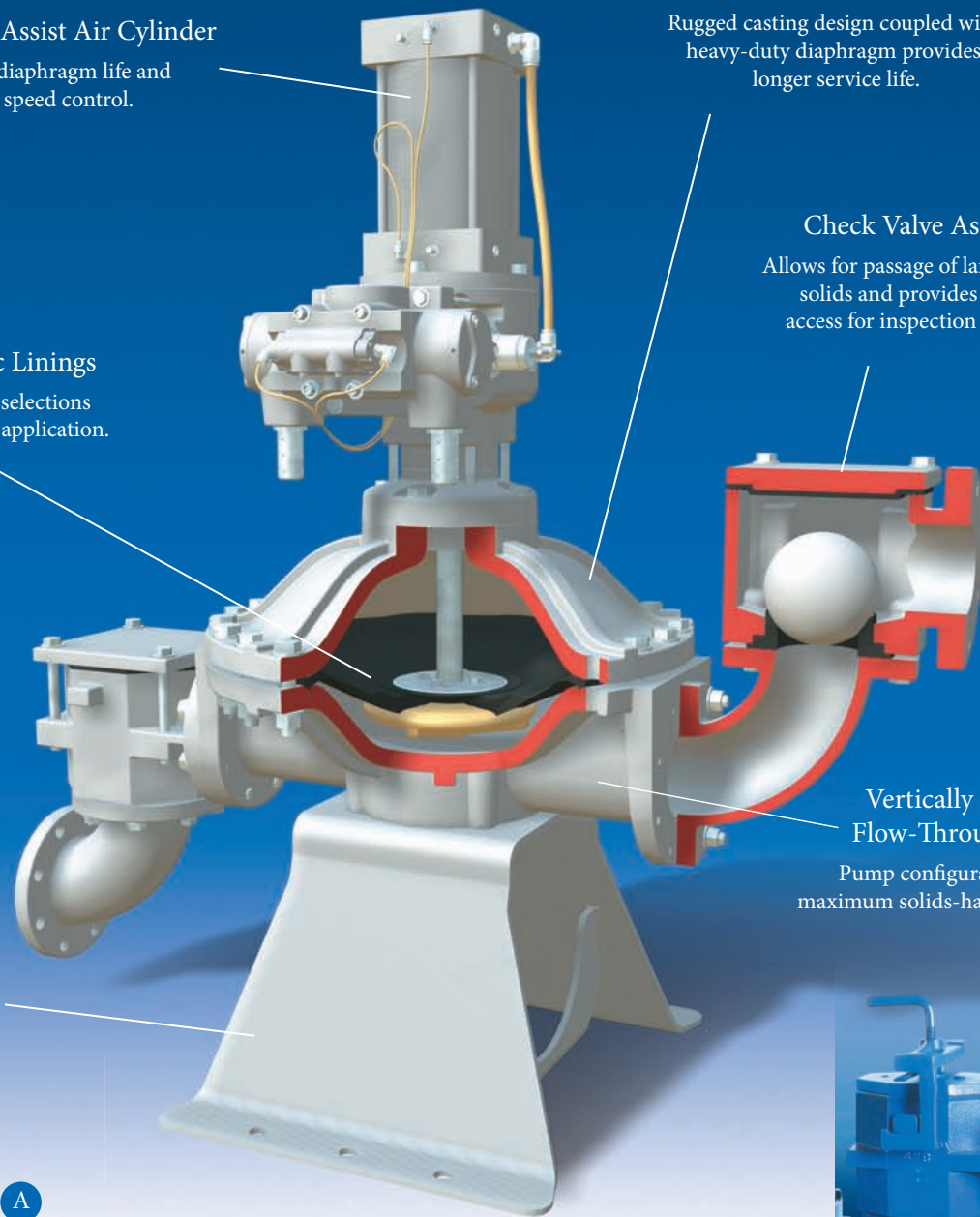

Optional "Twist Lok" Yoke

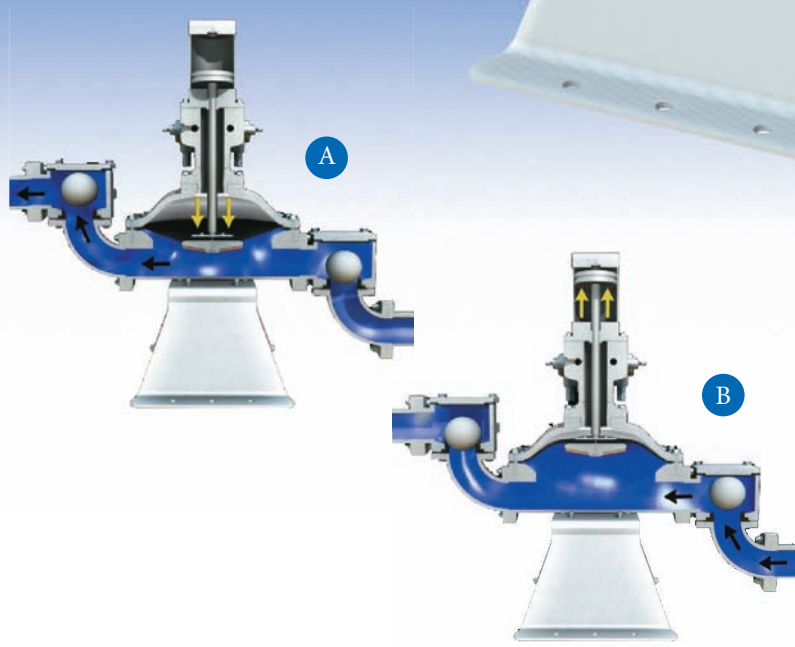

- A** Compressed air applied to the top of diaphragm pushes the diaphragm down, closing the suction check valve and forcing the liquid out through the discharge check valve.
- B** Compressed air is then directed into the bottom of the air cylinder, raising the air cylinder piston and retracting the diaphragm. The retracting diaphragm creates a vacuum, which closes the discharge check valve and fills the pump cavity through the suction check valve for the next stroke. Used air is exhausted to the atmosphere.

RUGGED

Choose from Nine High Performance Models

MODEL	DISCHARGE SIZE	TYPICAL FLOW RANGE*	TYPICAL DISCHARGE HEAD*	TYPICAL STROKES PER MINUTE*	MAX. SOLIDS
15-IC / 15P	1½" (40 mm)	1-15 gpm (0.06 - 0.95 lps)	20' - 150' (6 m - 40 m)	2 - 30	1" (25.4 mm)
20-IC / 20P	2" (50 mm)	3-37 gpm (0.19 - 2.3 lps)	20' - 150' (6 m - 40 m)	2 - 30	1" (25.4 mm)
30-IC	3" (75 mm)	6-75 gpm (0.38 - 4.73 lps)	20' - 150' (6 m - 40 m)	2 - 30	1⅛" (28.6 mm)
30P	3" (75 mm)	10-125 gpm (0.63 - 7.9 lps)	20' - 150' (6 m - 40 m)	2 - 30	1⅛" (28.6 mm)
40-IC / 40P	4" (100 mm)	15-145 gpm (0.95 - 9.1 lps)	20' - 150' (6 m - 40 m)	2 - 30	1⅛" (28.6 mm)
60P	6" (150 mm)	20-315 gpm (1.26 - 19.9 lps)	20' - 150' (6 m - 40 m)	2 - 30	2½" (63.5 mm)

*Maximum flow, head and strokes per minute exceed typical ranges. Consult factory for specific information.

Efficient Air Cylinder Design

Both the iPC™ and the P. Series of RAMPARTS A.D.D. pump designs incorporate this feature. The diaphragm-assist air cylinder offers virtually no resistance as the pump moves through its discharge stroke. Competitive pumps utilize a spring-assist design that requires more energy to operate the pump.

RAMPARTS A.D.D. pumps offer longer diaphragm life and reduced air consumption as a result of this design.

Air-driven diaphragm pumps have no close tolerance assemblies, so maintenance and service are minimal.

RAMPARTS A.D.D. pumps employ externally accessible check valve assemblies. Both the bolted and 'twist lok handle/yoke' designs allow check valves to be quickly and easily inspected, cleaned or serviced.

Rugged Construction

With their rugged ductile iron bolted castings, standard RAMPARTS A.D.D. Pumps can handle mildly corrosive and abrasive applications with ease. A wide range of elastomers linings is available for more extreme applications.

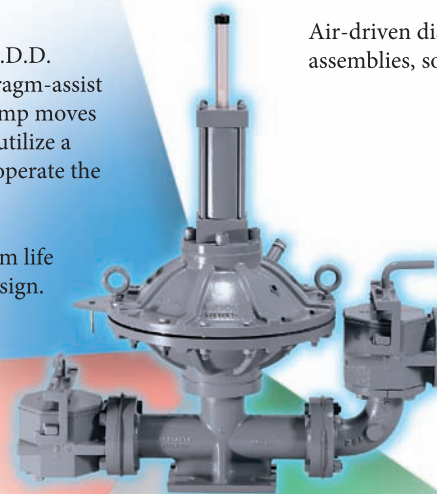

Service and Repair Features

In most applications, RAMPARTS A.D.D. pumps can be easily serviced in-line using simple hand tools and techniques.

Superior Solids-Handling Design

The vertical orientation of the pump diaphragm and the flow-through layout of the check valve and pump body allow for handling concentrated slurries and sludge as well as large solids. The design has been proved superior to conventional pump designs RAMPARTS A.D.D. pumps compete against.

RAMPARTS A.D.D. pumps utilize many common components, reducing parts inventory costs as compared with competitive diaphragm pumps. Their maintenance-friendly design allows service to be performed by one person in most applications.

Product information is subject to change; consult factory for details.

RamParts® Pumps

4855 Broadmoor Ave. - Kentwood, MI. 49512 - Ph. 616.656-2250 Fax 616.656-2255

www.RamPartspumps.com